



 **2011**

RAIL Strip Lighting

Strip Lighting

Strip Lighting

Recess-mounted linear luminaires as individual luminaires or as a custom-length system are used in prestigious rooms and in thoroughfares. Strip lighting delineates an area and, if required, can serve to underline architectural lines or to provide homogenous illumination of general areas. The systems can be used in wall and ceiling areas.

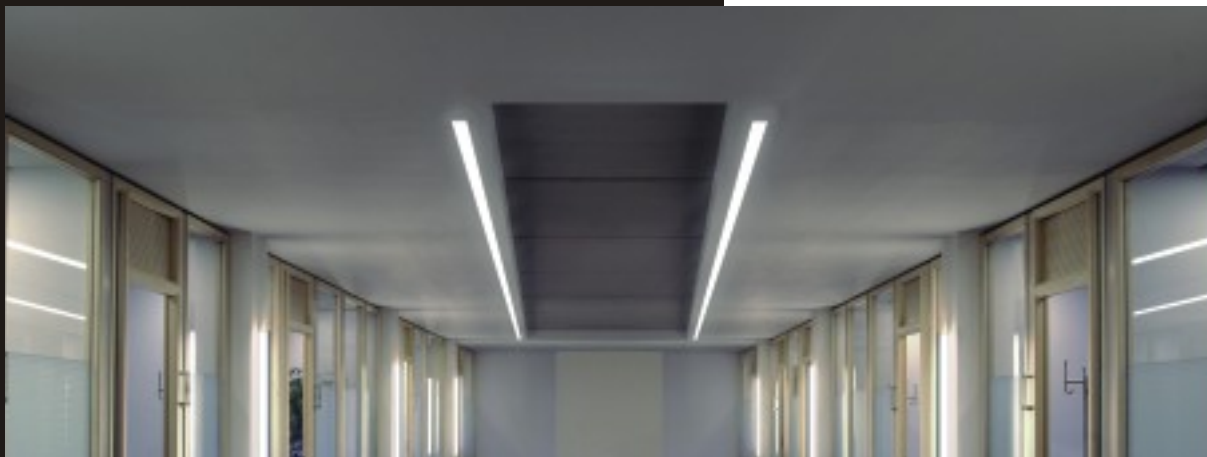

Strip Lighting

Freely extendable lighting channel made of aluminium profile with different inserts. Suitable for vertical and horizontal mounting. Available as a frameless version or with a filigree all-round edge profile. Can be used to provide luminaire arrangements functioning as ambient lighting and/or as accent lighting. The cover of the strip lighting is made of opal acrylic with satinized surface. The miniaturised louvred luminaires have high-quality parabolic specular louvres made of aluminium. Spotlight systems and building technology components can be integrated into the system.

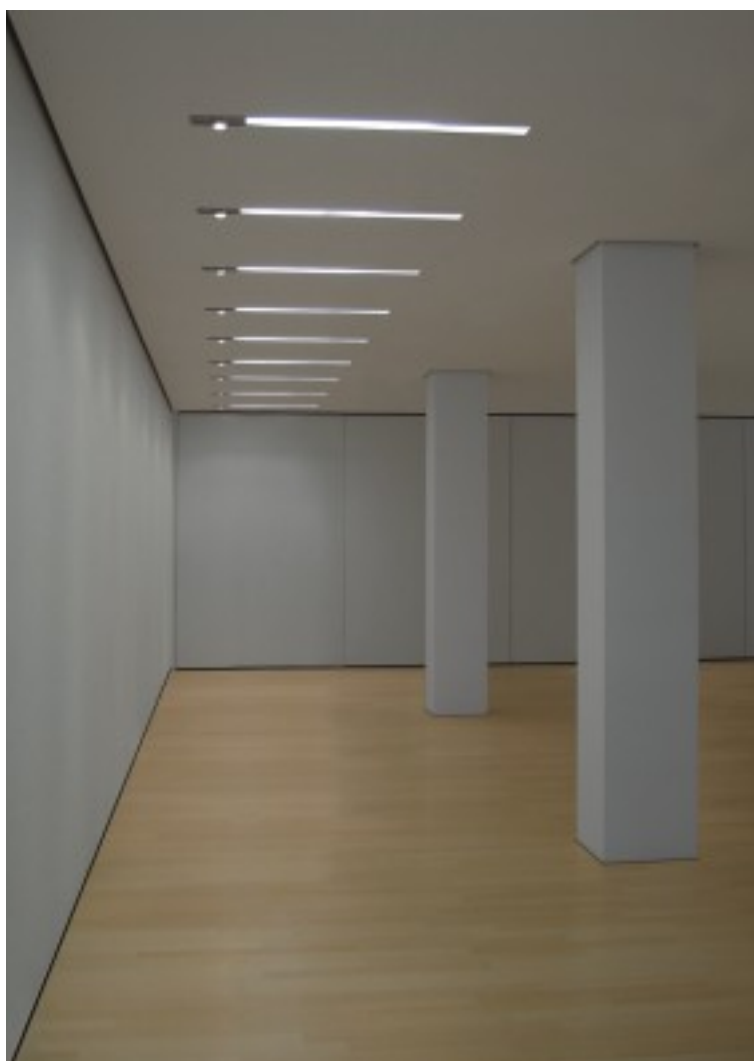

Strip Lighting

Lamp Overlap

When implementing the system, it is important to avoid the characteristic dark zones between one lamp and the next by overlapping the lamps.

Our system luminaires have been specially designed for this type of application. The illuminating surface of the diffuser is illuminated without any transitions or shadows.



Strip lighting with shadow-free acrylic lens

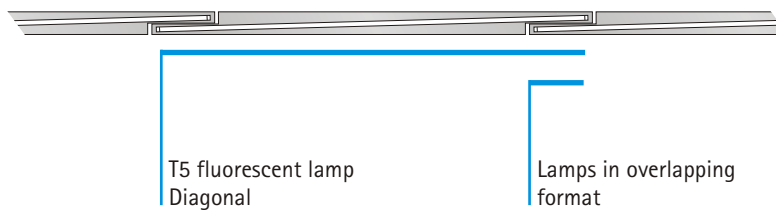

Diffuser

Cover designed as an acrylic diffuser. Satinized opal surface with high transmission factor for diffuse light distribution and glare-free light.

Parabolic Louvre

The parabolic louvres used are fitted as a continuously louvred strip with end plates. Our aluminium louvres are noted for their high efficiency and good glare control. They are suitable for use with computer workstations and for professional use in offices.

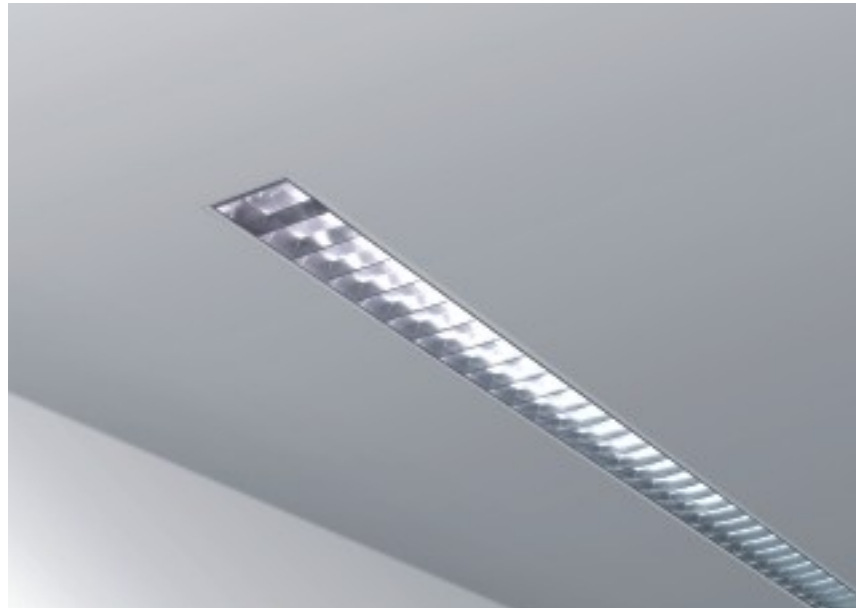
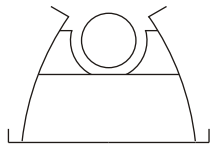

Strip lighting with parabolic louvre



Can be fitted as a continuously louvred strip or positioned anywhere in the profile with blank covers over the empty elements.



Parabolic Louvre

Parabolic louvre with highly reflective surfaces. Aluminium with reflection-intensifying coating to increase the light output ratio. CAT 2

Strip Lighting



Dual Light

To provide scenic light, spot-light inserts are available. Highly diverse lighting moods can be created by using different light sources. Diffuse and pin-pointed light are combined as a double function in one luminaire that does not come to the fore itself. The even ambient light produced by the T5 fluorescent lamps is complemented by additional, independent lighting.

Spotlight Module

When combined with fixed or adjustable projection inserts, high vertical accentuation is possible. Light sources for the auxiliary lighting are halogen lamps in low voltage, ceramic HID lamps - such as BriteSpot Es50 - and LED.



Fixed luminaire inserts



Tiltable luminaire inserts

STORR



RAIL+



RAIL



Spot, fixed



Spot, tiltable



T5 / LED Lighting Control

Altering the colour temperatures in line with the colour progression of natural light is, alongside brightness, the most significant factor when implementing biologically regulated light. In this way, periods of activity and rest can both be supported practically.

A program control with pre-defined light scenes up to and including dynamic colour temperature is possible as an optional extra.

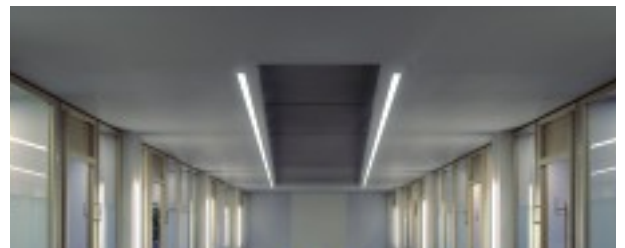
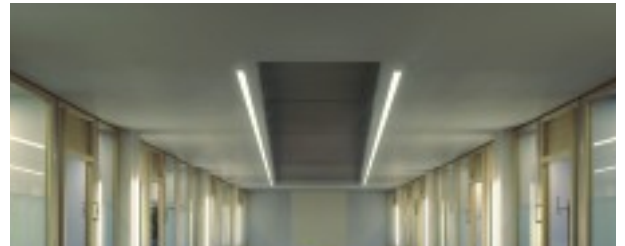

LED / RGB Strip Lighting

The additive colour mixing in infinitely adjustable colour spectra enable scenic colour changing, decorative and inspiring light or colour matching to suit the natural dynamics of our surroundings.

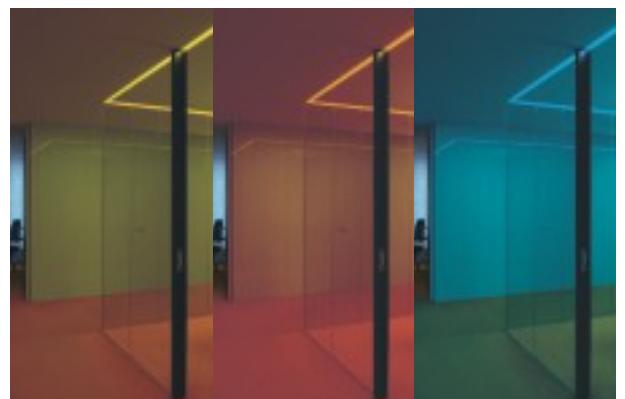

Strip Lighting

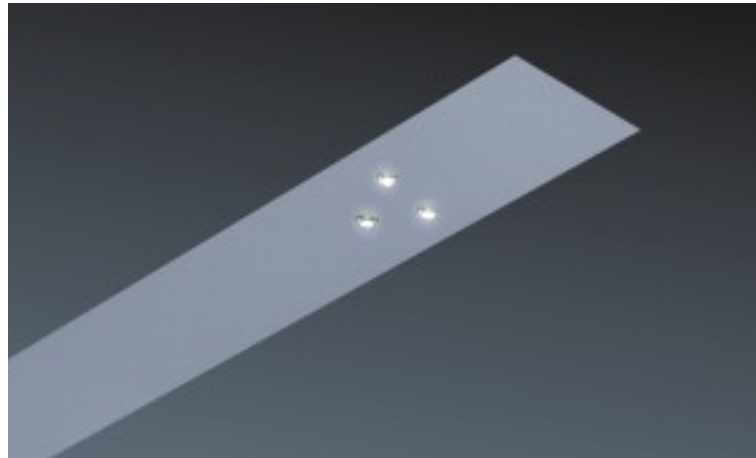

Safety Luminaires

Independent luminaire inserts with or without single batteries are integrated as system elements in a non-maintained circuit. A wide variety of wattages allows the emergency lighting units to be used as safety or secondary lighting. Rescue signs can be integrated in continuous circuits or into reference luminaires by using optical lighting accessories. Easy revision of the additional elements allows usage of single batteries.

LED Emergency Module

Specific components such as monitoring modules, AC/DC switching points, address modules and individual batteries can be integrated for the emergency lighting function.



Emergency lighting unit
single battery
with control LED

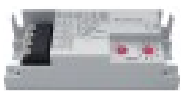

Monitoring component



Change-over relays



Multifunctional Luminaires

Holistic concepts in building engineering decrease construction costs and increase flexibility. Here multifunctional luminaires offer a solution through an increased system integration without affecting the interior design. System adaptors or complete system elements realize the connection to building engineering. Project related realization should be clarified in detail.

STORR



RAIL+



RAIL



Air-conditioning technology



Sensor



Loudspeakers



Fire alarm detectors



Water sprinkler preparation



Fire Alarm Detectors

In principle conventional fire alarm detectors can also be integrated as a system element into the multifunctional luminaires. To ensure conformity with the current German VDE guidelines, the possibility of integration must be checked in detail and must be confirmed by the fire alarm detector manufacturer with a certificate of compliance (German regulation for the German market).

Water Sprinkler

System adaptors allow the installation of a covering plate with 50mm cut out hole. Avoiding frictional connected luminaire the installation of suspended screen sprinklers and the supply of the sprinkler pipes can be realized.

A certificate of compliance by the water sprinkler manufacturer is recommended.

Tone

Wide band loudspeakers are available as a system element. They integrated, aligned and reversible through bayonet lock.

Special Equipment

Besides the mentioned basic elements further technical elements can be integrated in addition to the indicated basic modules. This includes: video monitors; alarm and sensor technology; revision elements for control valves and maintenance elements.

Air Conditioning Technology

In addition to the harmonious design styling, the combination

of air conditioning and lighting technology also reduces installation time by reducing the ceiling cut-outs. System adaptors allow the integration of additional elements at the same time fulfilling various climatic demands. A spatial separation of individual technical elements guarantees highly efficient individual functions. Controllable integration of air input and output.

Strip Lighting with Frame

Various mounting options are available for installation purposes. Please see below for an overview of the most commonly used systems. Project specific solutions are also possible and are solved by our design team.

RAIL

STORR



SYSTEM K
Mounting on stud bolts

Screw fixing for cut ceiling systems, for retro-fitting on threaded bar.

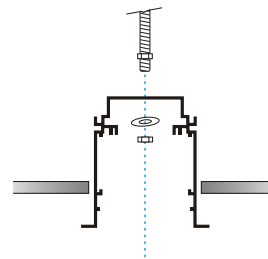
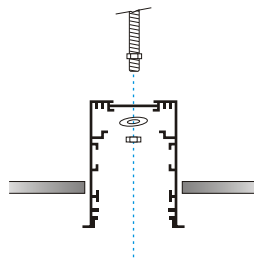

SYSTEM H
Mounting on auxiliary construction

Screw fixing for cut ceiling systems, for retro-fitting on a previously installed mounting construction.

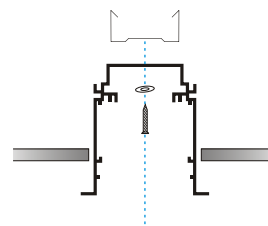
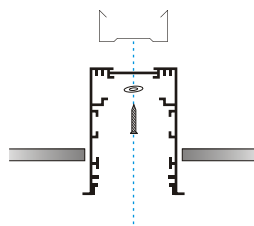

SYSTEM B
Wire rope suspension with rapid connector system

Wire-rope suspension for mounting the luminaire to the bare ceiling. For retro-fitting to suspended ceiling.

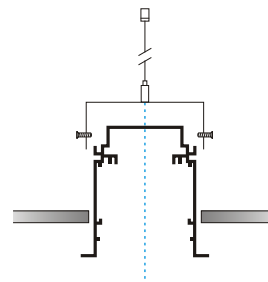
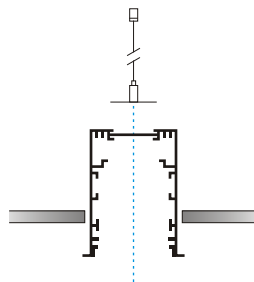



SYSTEM M
Mounting with
stirrup M

Bracket-mounting for cut ceiling systems for retro-fitting on a suspended-ceiling construction to be fabricated on-site.

- 1 Insert the mounting bracket into the ceiling cut-out and secure in position

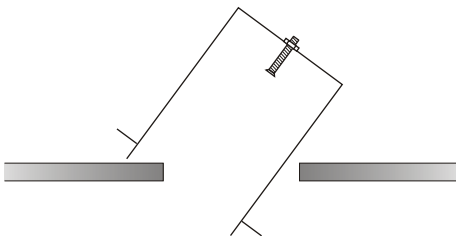

- 2 Insert the mounting plate

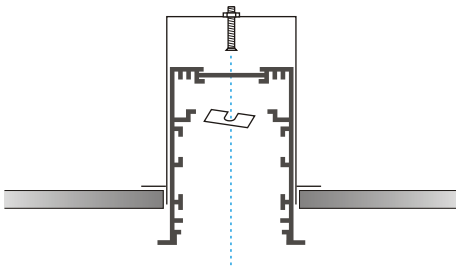

- 3 Tighten screw

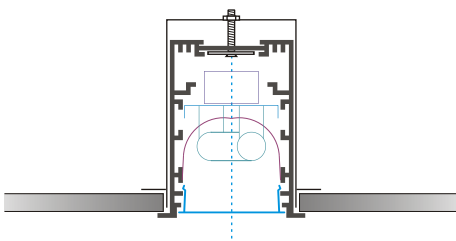

- 4 Connect the equipment carrier, screw in place, fit the lamps and check proper operation.

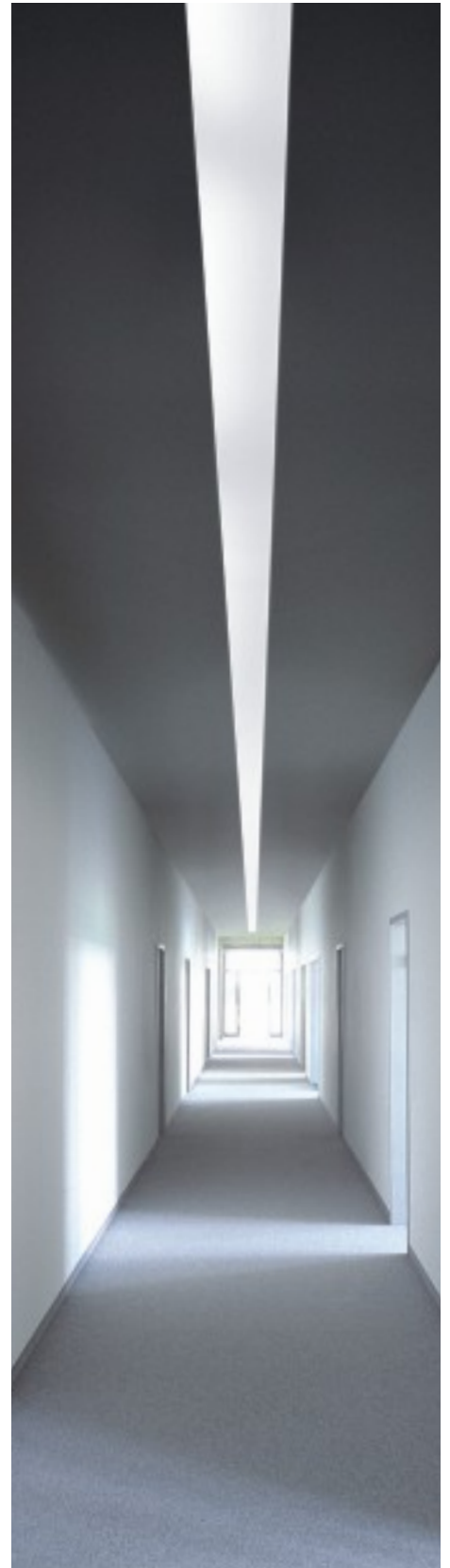

Strip Lighting Frameless

Various mounting options are available for installation purposes. Please see below for an overview of the most commonly used systems. Project specific solutions are also possible and are solved by our design team.

 **SYSTEM K**
Mounting on stud bolts

Screw fixing for cut ceiling systems, for retro-fitting on threaded bar.

RAIL+

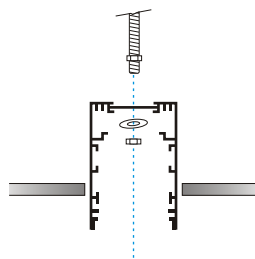

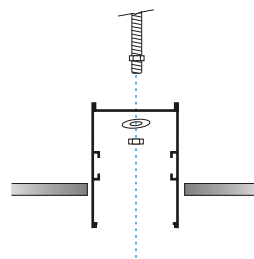

RAIL

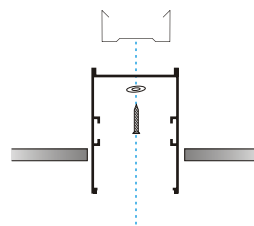
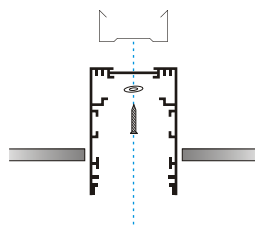

 **SYSTEM H**
Mounting on auxiliary construction

Screw fixing for cut ceiling systems, for retro-fitting on a previously installed mounting construction.



 **SYSTEM L**
Mounting with angle bracket

For mounting to a bare ceiling, then fitting the suspended ceiling to the luminaire profile.

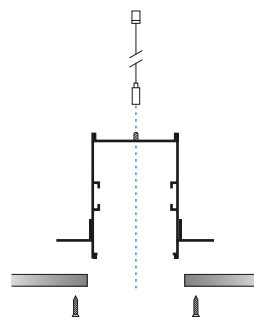
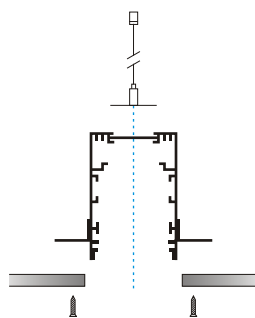

 **SYSTEM M**
Mounting with stirrup M

Bracket-mounting for cut ceiling systems for retro-fitting on a suspended-ceiling construction to be fabricated on-site.

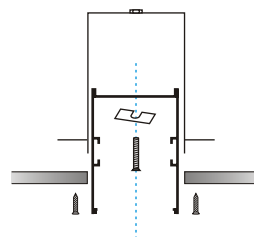
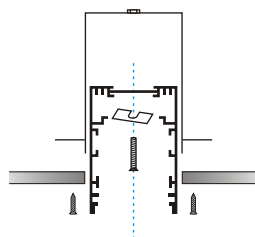

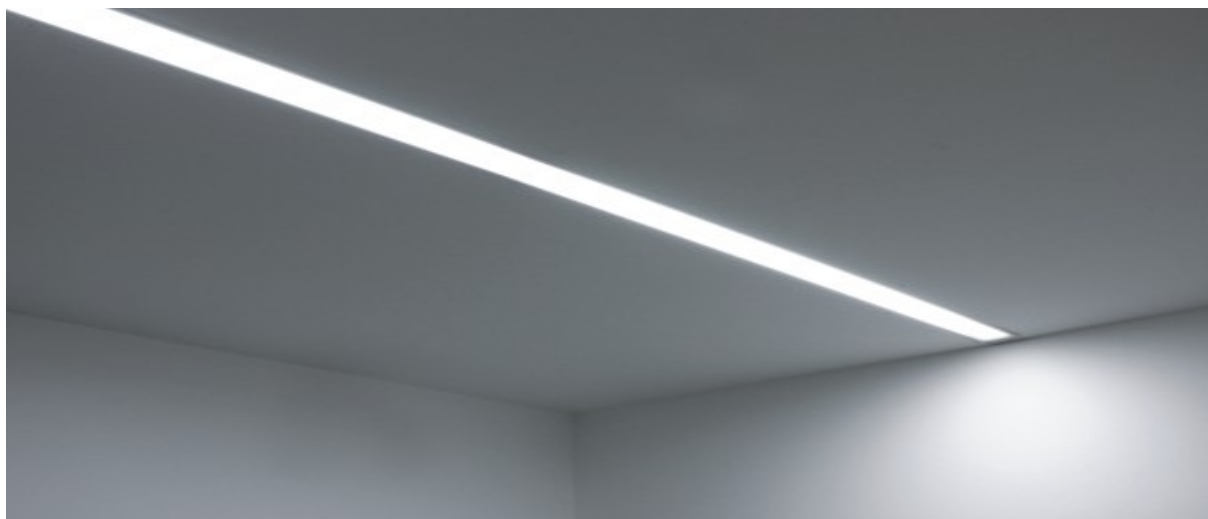

The plastered-in mounting allows the luminaire to be fully integrated into the building structure. To achieve a perfect result, the luminaires must be mounted and fitted with the utmost care. The expansion joint mentioned here is an absolute necessity.

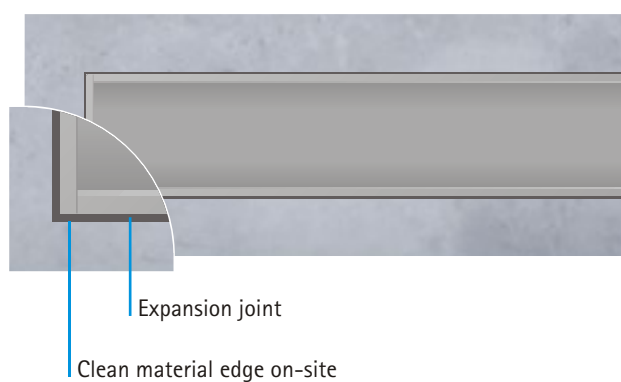
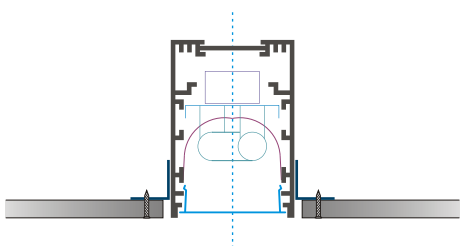

Steps

1. Insert permanently elastic expansion joint
2. Fit plaster gauze over transitions
3. Fill and plaster
4. Paint

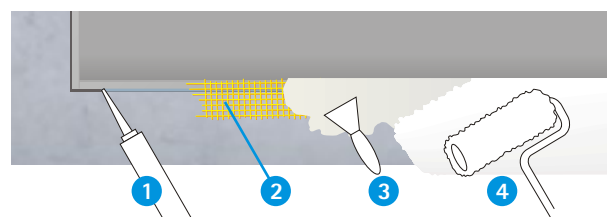

Strip Lighting Frameless

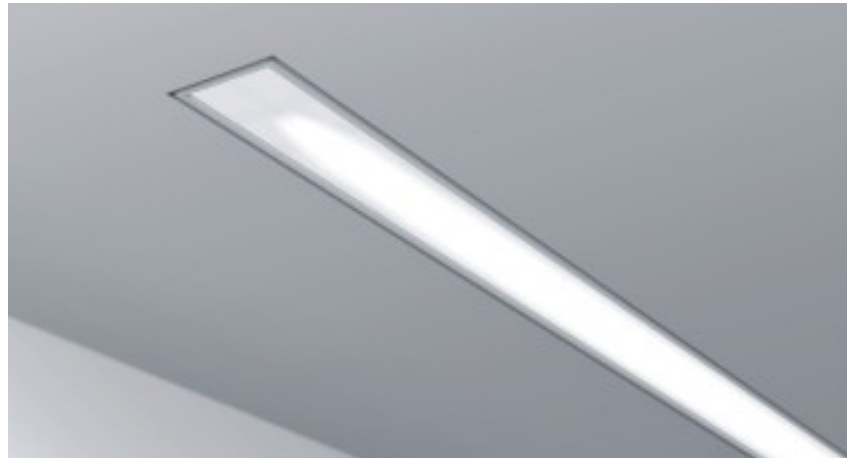

As an alternative to the above-mentioned flush-plastered mounting, the installation with shadow gap is also recommendable. A cleanly finished ceiling cut-out can be easily produced using precast plaster parts or plaster rails. Various concrete installation housings are also available for our strip lights.

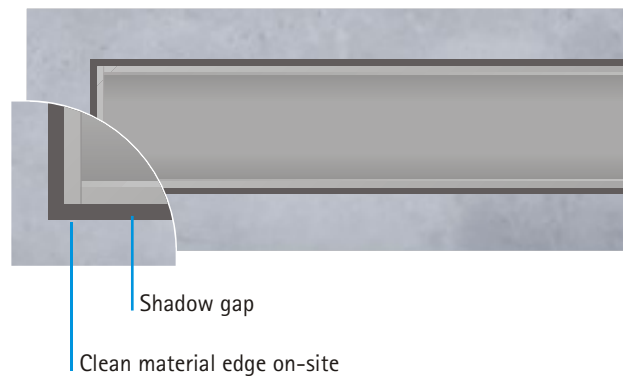

Wall-mounting the luminaire with wall bracket with predefined offset from wall. Fitting to the ceiling with joint. Ceiling finished with finishing profile.

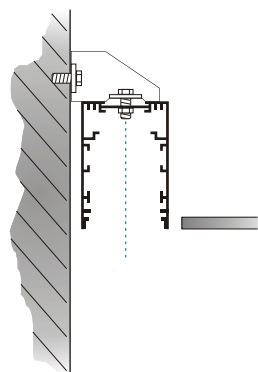

Ceiling cut-out to be produced on-site by the ceiling builder. Ceiling finished with finishing profile.

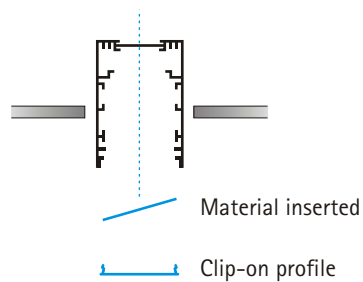

Ceiling cut-out produced very exactly on-site using solid ceiling plaster profiles.

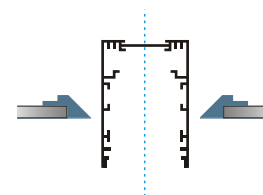

Using individually precast, shaped plaster parts produces a unified appearance of the ceiling system and luminaire. The shaped plaster parts are designed to fit the luminaires to be installed, ensuring uncomplicated installation by the specialist fitters. The variety of shapes is limitless, giving

the designer every possibility to be creative. We are happy to provide support for the technical implementation and can name suppliers once the requirements have been fixed.

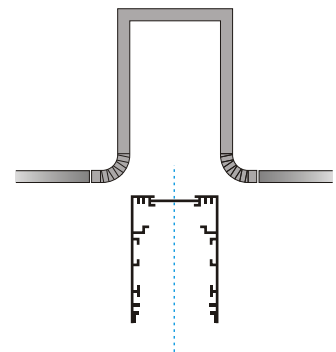
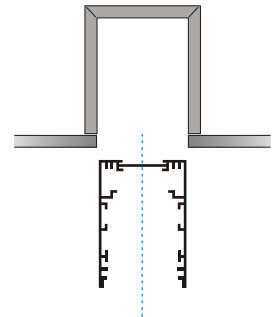

Cast in Concrete

Direct mounting of the aluminium profiles is enabled using wooden cores on the concrete formwork. These have two to four insertion openings for the conduit. Mounting using internal mounting plates is provided in order to enable installation in bare concrete ceilings. Please indicate separately when ordering.

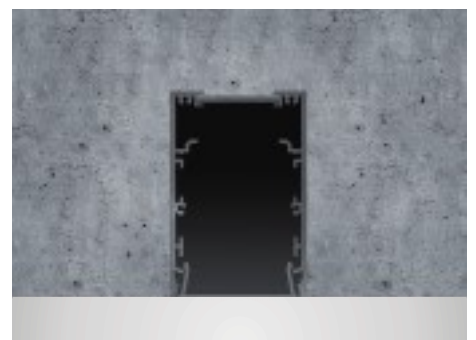

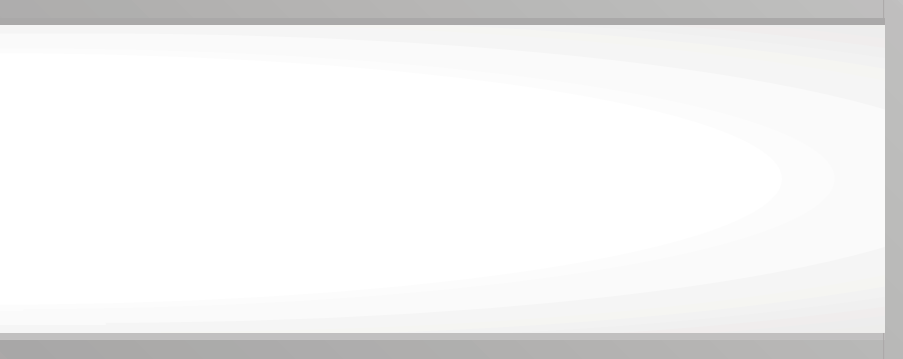

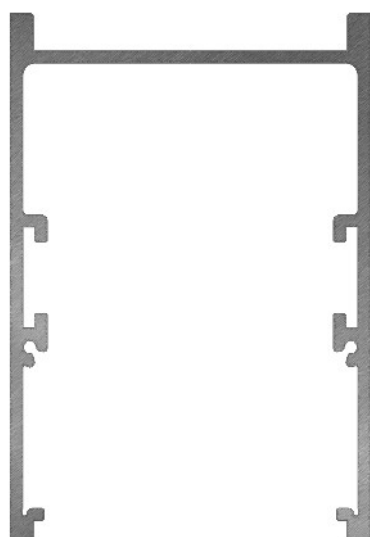

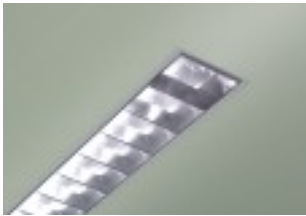
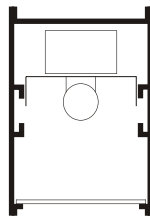
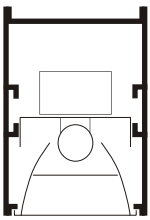

Parabolic Louvre

Parabolic louvre with highly reflective surfaces. Aluminium with reflection-intensifying coating to increase the light output ratio. CAT 2



Diffuser

Cover designed as an acrylic diffuser. Satinized opal surface with high transmission factor for diffuse light distribution and glare-free light.

RAIL

For luminaires with direct light distribution, the aluminium parabolic louvres are available in two different louvre heights. Both louvre types are compatible for use with computer workstations. The shallow version has very good glare control, CAT 2, combined with optimum efficiency and has a wide-beam light distribution. The high cross louvre ensures maximum glare control, CAT 1. Computer-workstation compatible, featuring a Darklight lens system. The louvres are fitted all the way along. In addition, this profile is also available as a surface mounted strip light, whereby the lamp is covered by a recessed opal diffuser in satin-frosted white.



Inserted Materials

With this profile, the luminaire covers are inserted. This means that in addition to the diffusers that have a purely technical function, decorative diffusers can also be fitted. Highly diverse materials are available.



Acrylic with linear anti-glare prism

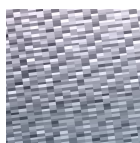

Acrylic with conical anti-glare prism



Coloured acrylic



Satinized glass

RAIL Strip Lighting

RAIL Individual Luminaire

As a design aid we distinguish between individual luminaires and system luminaires. Individual luminaires are ready-to-connect one-piece units. They are prepared for installation as per mounting system H. The delivery includes the system related accessories including the end plates, the electrical components and the lens system.

Mounting Systems:



SYSTEM K
Mounting on stud bolts



SYSTEM H
Mounting on auxiliary construction



SYSTEM M
Mounting with stirrup

Unit length for RAIL luminaire row:

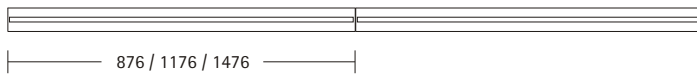

Unit length for RAIL strip lighting:

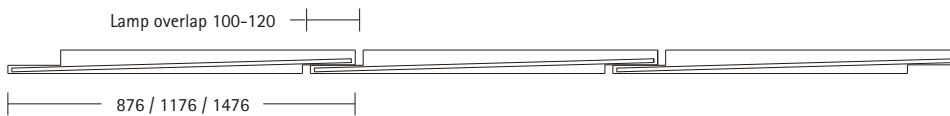

RAIL Strip Lighting

Individual luminaires made of sharp-edged extruded aluminium profile in trimless design. Complete luminaire with integrated MultiPower electronic control gear. Equipped for T5 fluorescent lamps, optionally HO or HE.

Wired ready-to-connect with heat resistant cable. Luminaire cover optionally available with computer-workstation compatible aluminium parabolic louvre or with wide-beam, opal, acrylic diffuser.

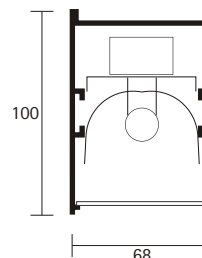

			T16 HO 	39W G5	49W G5	54W G5	80W G5
			T16 HE 	21W G5	28W G5	35W G5	

							Version					
							Parabolic louvre	Acrylic diffuser	White	Silver C3	Made to RAL	Anodized aluminium
							Article No.	ECG	Lamp version			
Single luminaire												
	ED= 68x 880mm	CCO=69x 881mm	1750.121	-.02	1 x 1 x T16	21/39W	●		●	○	○	○
	ED= 68x1180mm	CCO=69x1181mm	1750.128	-.02	1 x 1 x T16	28/54W	●		●	○	○	○
	ED= 68x1480mm	CCO=69x1481mm	1750.135	-.02	1 x 1 x T16	35/49/80W	●		●	○	○	○
	ED= 68x1756mm	CCO=69x1757mm	1750.221	-.02	2 x 1 x T16	21/39W	●		●	○	○	○
	ED= 68x2356mm	CCO=69x2357mm	1750.228	-.02	2 x 1 x T16	28/54W	●		●	○	○	○
	ED= 68x2956mm	CCO=69x2957mm	1750.235	-.02	2 x 1 x T16	35/49/80W	●		●	○	○	○
Single luminaire												
	ED= 68x 880mm	CCO=69x 881mm	1751.121	-.02	1 x 1 x T16	21/39W	●		●	○	○	○
	ED= 68x1180mm	CCO=69x1181mm	1751.128	-.02	1 x 1 x T16	28/54W	●		●	○	○	○
	ED= 68x1480mm	CCO=69x1481mm	1751.135	-.02	1 x 1 x T16	35/49W	●		●	○	○	○
	ED= 68x1656mm	CCO=69x1657mm	1751.221	-.02	2 x 1 x T16	21/39W	●		●	○	○	○
	ED= 68x2256mm	CCO=69x2257mm	1751.228	-.02	2 x 1 x T16	28/54W	●		●	○	○	○
	ED= 68x2856mm	CCO=69x2857mm	1751.235	-.02	2 x 1 x T16	35/49W	●		●	○	○	○
	ED= 68x3292mm	CCO=69x3293mm	1751.328	-.02	3 x 1 x T16	28/54W	●		●	○	○	○
	ED= 68x4192mm	CCO=69x4193mm	1751.335	-.02	3 x 1 x T16	35/49W	●		●	○	○	○
	Ceiling thicknesses > 12mm							1750.080		Stirrup-M		



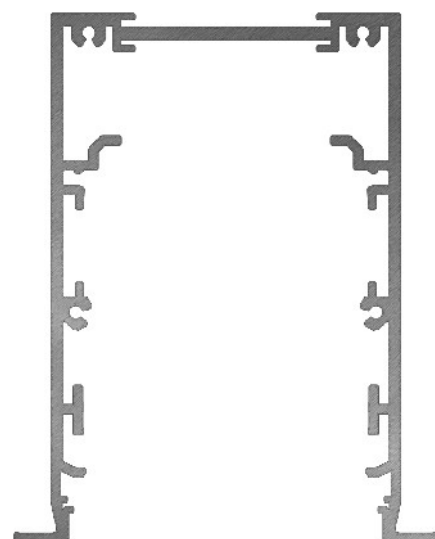
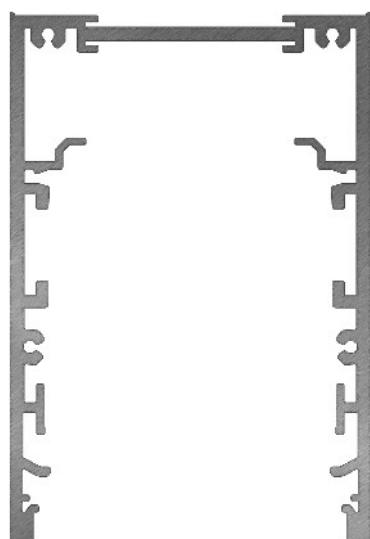

RAIL Strip Lighting

Strip Lighting Installation Profile

Special tasks require special solutions. The use of rigid aluminium profiles enables a wide variety of design possibilities. Clean transitions, horizontal or vertical corners, connectors, different lens systems and various luminaire inserts give the creative mind much freedom for design and are the basis for giving rooms a complete new feel.



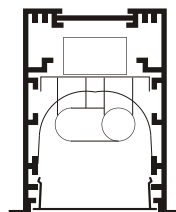
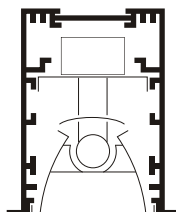
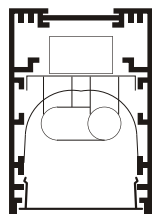
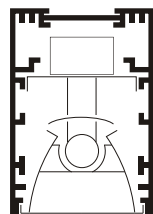

RAIL

This system is designed using empty profiles that are mounted in the ceiling and fitted with a wide range of luminaire inserts. For office applications it is possible to use fluorescent lamp modules with parabolic louvres made of high polish aluminium. Inserts for overlapping lamp arrangement are available to give a continuous, shadow-free strip of light. These light inserts act as the luminaire cover and, with their opal satinized surface finish, are light-dispersing diffusers with high transmittance. In addition, accentuating spotlights, blank covers and compartments for technical equipment can also be integrated into the system. The through-wiring is easily accessible and there is space for further cable routes.



Parabolic Louvre

Parabolic louvre with highly reflective surfaces. Aluminium with reflection-intensifying coating to increase the light output ratio. CAT 2

Diffuser

Cover designed as an acrylic diffuser. Satinized opal surface with high transmission factor for diffuse light distribution and glare-free light.

RAIL Strip Lighting

► Individual Luminaire

As a design aid we distinguish between individual luminaires and system luminaires. Individual luminaires are ready-to-connect one-piece units. They are prepared for installation as per mounting system H. The delivery includes the system related accessories including the end plates, the electrical components and the lens system.

RAIL Strip Lighting

Individual luminaires made of sharp-edged extruded aluminium profile. Complete luminaire with integrated MultiPower electronic control gear. Equipped for T5 fluorescent lamps, optionally HO or HE.

Mounting Systems:



SYSTEM K
Mounting on stud bolts



SYSTEM H
Mounting on auxiliary construction



SYSTEM M
Mounting with stirrup

Wired ready-to-connect with heat resistant cable. Luminaire cover optionally available with computer-workstation compatible aluminium parabolic louvre or with wide-beam, opal, acrylic diffuser.

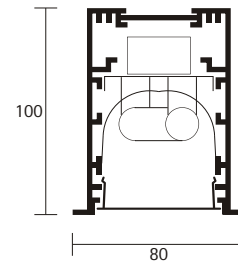
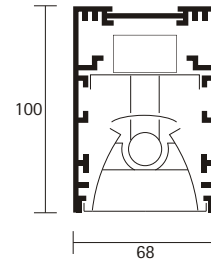

Unit length for RAIL luminaire row:



Unit length for RAIL strip lighting:

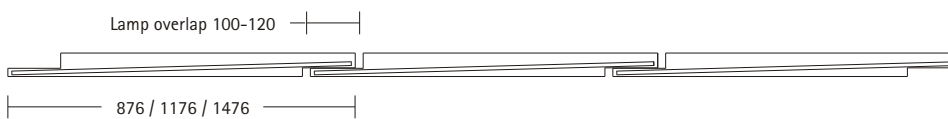



							Version										
							Parabolic louvre	Acrylic diffuser	White	Silver C3	Made to RAL	Anodized aluminium					
							Article No.	ECG	Lamp version								
RAIL, frameless (trimless)																	
	ED= 68x 880mm	CCO=69x 881mm	1753.121	-.02	1 x 1 x T16	21/39W	<input checked="" type="checkbox"/>		<input checked="" type="checkbox"/>	<input type="checkbox"/>	<input type="checkbox"/>	<input type="checkbox"/>	<input type="checkbox"/>				
	ED= 68x1180mm	CCO=69x1181mm	1753.128	-.02	1 x 1 x T16	28/54W	<input checked="" type="checkbox"/>		<input checked="" type="checkbox"/>	<input type="checkbox"/>	<input type="checkbox"/>	<input type="checkbox"/>	<input type="checkbox"/>				
	ED= 68x1480mm	CCO=69x1481mm	1753.135	-.02	1 x 1 x T16	35/49/80W	<input checked="" type="checkbox"/>		<input checked="" type="checkbox"/>	<input type="checkbox"/>	<input type="checkbox"/>	<input type="checkbox"/>	<input type="checkbox"/>				
	ED= 68x2356mm	CCO=69x2357mm	1753.228	-.02	2 x 1 x T16	28/54W	<input checked="" type="checkbox"/>		<input checked="" type="checkbox"/>	<input type="checkbox"/>	<input type="checkbox"/>	<input type="checkbox"/>	<input type="checkbox"/>				
	ED= 68x2956mm	CCO=69x2957mm	1753.235	-.02	2 x 1 x T16	35/49/80W	<input checked="" type="checkbox"/>		<input checked="" type="checkbox"/>	<input type="checkbox"/>	<input type="checkbox"/>	<input type="checkbox"/>	<input type="checkbox"/>				
RAIL, frameless (trimless)																	
	ED= 68x 880mm	CCO=69x 881mm	1754.121	-.02	1 x 1 x T16	21/39W		<input checked="" type="checkbox"/>	<input checked="" type="checkbox"/>	<input type="checkbox"/>	<input type="checkbox"/>	<input type="checkbox"/>	<input type="checkbox"/>				
	ED= 68x1180mm	CCO=69x1181mm	1754.128	-.02	1 x 1 x T16	28/54W		<input checked="" type="checkbox"/>	<input checked="" type="checkbox"/>	<input type="checkbox"/>	<input type="checkbox"/>	<input type="checkbox"/>	<input type="checkbox"/>				
	ED= 68x1480mm	CCO=69x1481mm	1754.135	-.02	1 x 1 x T16	35/49/80W		<input checked="" type="checkbox"/>	<input checked="" type="checkbox"/>	<input type="checkbox"/>	<input type="checkbox"/>	<input type="checkbox"/>	<input type="checkbox"/>				
	ED= 68x2256mm	CCO=69x2257mm	1754.228	-.02	2 x 1 x T16	28/54W		<input checked="" type="checkbox"/>	<input checked="" type="checkbox"/>	<input type="checkbox"/>	<input type="checkbox"/>	<input type="checkbox"/>	<input type="checkbox"/>				
	ED= 68x2856mm	CCO=69x2857mm	1754.235	-.02	2 x 1 x T16	35/49/80W		<input checked="" type="checkbox"/>	<input checked="" type="checkbox"/>	<input type="checkbox"/>	<input type="checkbox"/>	<input type="checkbox"/>	<input type="checkbox"/>				
RAIL with trim																	
	ED= 80x 895mm	CCO=69x 881mm	1755.121	-.02	1 x 1 x T16	21/39W	<input checked="" type="checkbox"/>		<input checked="" type="checkbox"/>	<input type="checkbox"/>	<input type="checkbox"/>	<input type="checkbox"/>	<input type="checkbox"/>				
	ED= 80x1195mm	CCO=69x1181mm	1755.128	-.02	1 x 1 x T16	28/54W	<input checked="" type="checkbox"/>		<input checked="" type="checkbox"/>	<input type="checkbox"/>	<input type="checkbox"/>	<input type="checkbox"/>	<input type="checkbox"/>				
	ED= 80x1495mm	CCO=69x1481mm	1755.135	-.02	1 x 1 x T16	35/49/80W	<input checked="" type="checkbox"/>		<input checked="" type="checkbox"/>	<input type="checkbox"/>	<input type="checkbox"/>	<input type="checkbox"/>	<input type="checkbox"/>				
	ED= 80x2372mm	CCO=69x2357mm	1755.228	-.02	2 x 1 x T16	28/54W	<input checked="" type="checkbox"/>		<input checked="" type="checkbox"/>	<input type="checkbox"/>	<input type="checkbox"/>	<input type="checkbox"/>	<input type="checkbox"/>				
	ED= 80x2972mm	CCO=69x2957mm	1755.235	-.02	2 x 1 x T16	35/49/80W	<input checked="" type="checkbox"/>		<input checked="" type="checkbox"/>	<input type="checkbox"/>	<input type="checkbox"/>	<input type="checkbox"/>	<input type="checkbox"/>				
RAIL with trim																	
	ED= 80x 895mm	CCO=69x 881mm	1756.121	-.02	1 x 1 x T16	21/39W		<input checked="" type="checkbox"/>	<input checked="" type="checkbox"/>	<input type="checkbox"/>	<input type="checkbox"/>	<input type="checkbox"/>	<input type="checkbox"/>				
	ED= 80x1195mm	CCO=69x1181mm	1756.128	-.02	1 x 1 x T16	28/54W		<input checked="" type="checkbox"/>	<input checked="" type="checkbox"/>	<input type="checkbox"/>	<input type="checkbox"/>	<input type="checkbox"/>	<input type="checkbox"/>				
	ED= 80x1495mm	CCO=69x1481mm	1756.135	-.02	1 x 1 x T16	35/49/80W		<input checked="" type="checkbox"/>	<input checked="" type="checkbox"/>	<input type="checkbox"/>	<input type="checkbox"/>	<input type="checkbox"/>	<input type="checkbox"/>				
	ED= 80x2272mm	CCO=69x2257mm	1756.228	-.02	2 x 1 x T16	28/54W		<input checked="" type="checkbox"/>	<input checked="" type="checkbox"/>	<input type="checkbox"/>	<input type="checkbox"/>	<input type="checkbox"/>	<input type="checkbox"/>				
	ED= 80x2872mm	CCO=69x2857mm	1756.235	-.02	2 x 1 x T16	35/49/80W		<input checked="" type="checkbox"/>	<input checked="" type="checkbox"/>	<input type="checkbox"/>	<input type="checkbox"/>	<input type="checkbox"/>	<input type="checkbox"/>				
	Ceiling thicknesses > 12mm Width of cut-out 72mm		1750.080		Stirrup-M												

RAIL Strip Lighting



RAIL Strip Lighting

A system luminaire installation as a modular toolbox, consisting of sharp-edged, drawn aluminium extrusions in trimless design or in a version with a narrow, all-round edge frame. Mounting strips with integrated MultiPower electronic control gear. Equipped for T5 fluorescent lamps, optionally HO or HE. Prewired with heat-resistant cable and ready-to-connect. Luminaire cover is optionally available with computer-workstation compatible aluminium parabolic louvre or with wide-beam, opal, acrylic diffuser.

► Louvre Spacing

The various louvre dimensions are dictated by the different lamp positions. With individual luminaires and with system luminaires that have louvres there is no overlapping arrangement of the fluorescent lamps. Therefore the construction dimension = lamp length plus lampholder.

Unit length for RAIL strip lighting:

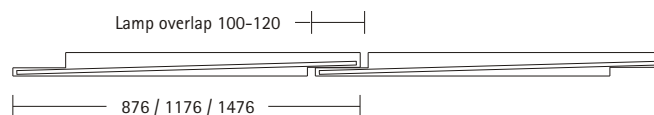

Unit length for RAIL luminaire row:



► **System Luminaire**

Lighting channel system designed as a custom-length luminaire with which different system components can be individually combined. This makes it possible for luminaire arrangements that delineate a room or area to be realised according to the designer's plans. The detailed design-work for such a system can be done directly and easily.

System Luminaire Options

Luminaire profile, empty

- Profile frameless (Trimless)
- Profile with edge frame

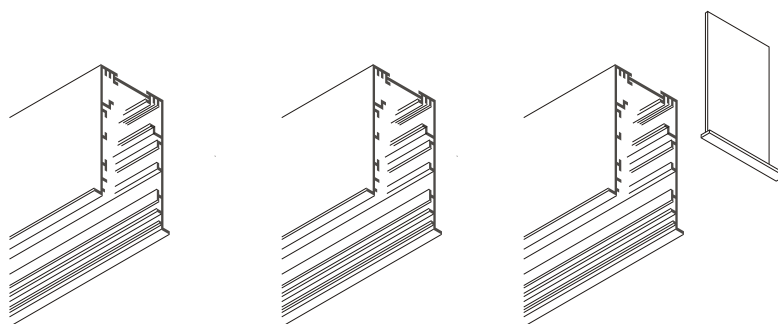

Light Unit

- Unit with parabolic louvre
- Unit with reflector for fluorescent lamp
- Unit with reflector for overlapping lamps

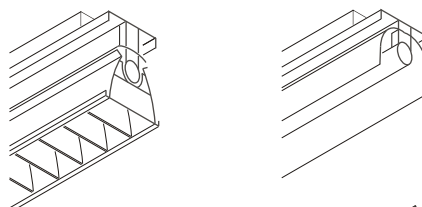

Luminaire Cover

- Blank aluminium profile
- Acrylic diffuser

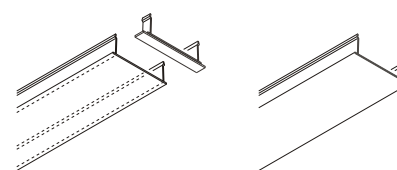

Operating Equipment Order Codes

- .01 Low-loss control gear
- .02 Electronic control gear
- .03 Dimmable ECG 1-10 volt
- .04 2 x individual ECG
- .05 2 x dimmable ECG 1-10 volt
- .10 Dimmable ECG DALI
- .11 2 x dimmable ECG DALI

Colour Key

- .-14 Anodized aluminium
- .-20 Made to RAL
- .-23 Silver C3
- .-25 Titanium silver
- .-31 White
- .-32 Matt white

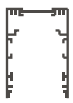

RAIL+ frameless
(Trimless)

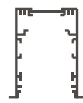

RAIL+ with frame
(Frame)



End cover
Art. No. 1762.099



End cover
Art. No. 1763.099



T-connector
Art. No. 1762.095



T-connector
Art. No. 1763.095



L-connector
angle 90°
Art. No. 1762.093



L-connector
angle 90°
Art. No. 1763.093



L-connector
special angle
Art. No. 1762.090



L-connector
special angle
Art. No. 1763.090



Straight connector
Art. No. 1762.098



Spacing cover
Art. No. 1764.099



Mounting brackets, system M
1750.080 For ceiling thicknesses 12mm
Width of cut-out 72mm



Wire-rope suspension, system B
1762.111 wire rope L= 1000mm
1762.112 wire rope L= 2000mm



Wire-rope suspension with canopy and cable
1762.121 wire rope L= 1000mm
1762.122 wire rope L= 2000mm

► System Components

The system components shown here are just a small excerpt of the current range of accessories that are available. More detailed design documents and an overview of the entire product range can be downloaded from our homepage as PDF files.

Mounting Systems:



SYSTEM K
Mounting on stud bolts



SYSTEM H
Mounting on auxiliary construction



SYSTEM M
Mounting with stirrup



Through-wiring

3-pole	Butted lamps
1770.321	for luminaire insert 21W
1770.328	for luminaire insert 28W
1770.335	for luminaire insert 35W

3-pole	Overlapping lamps
1772.321	for luminaire insert 21W
1772.328	for luminaire insert 28W
1772.335	for luminaire insert 35W



5-pole	Butted lamps
1770.521	for luminaire insert 21W
1770.528	for luminaire insert 28W
1770.535	for luminaire insert 35W





5-pole	Overlapping lamps
1772.521	for luminaire insert 21W
1772.528	for luminaire insert 28W
1772.535	for luminaire insert 35W

► To specify the profile's length, the placeholders ".xxx" are replaced by the length in cm.

Ordering example:

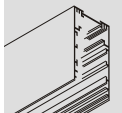
Empty profile RAIL+ with frame
Length 3100mm in white would be:
Art. No.: 1761.310.00.32

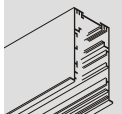

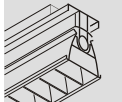
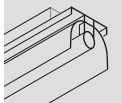
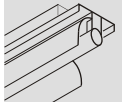
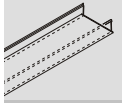
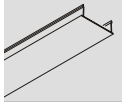
						Version					
		Article No.		Lamp version		Anodized E6EV1	White	Made to RAL	Not dimmable	DALI, dimmable	1-10 volt, dimmable
RAIL, frameless (trimless)											
		W = 68mm	1760.xxx	Empty profile in metres		<input checked="" type="radio"/>	<input type="radio"/>	<input type="radio"/>			
		CCO = 69mm	1760.000	Sawn	to size						
RAIL with frame											
		W = 80mm	1761.xxx	Empty profile in metres		<input checked="" type="radio"/>	<input type="radio"/>	<input type="radio"/>			
		CCO = 69mm	1761.000	Sawn	to size						
Luminaire insert with parabolic louvre											
		Length 875mm	1770.121	.-02	1 x T16				<input checked="" type="radio"/>	<input type="radio"/>	<input type="radio"/>
		Length 1175mm	1770.128	.-02	1 x T16				<input checked="" type="radio"/>	<input type="radio"/>	<input type="radio"/>
		Length 1475mm	1770.135	.-02	1 x T16				<input checked="" type="radio"/>	<input type="radio"/>	<input type="radio"/>
Luminaire insert with reflector (without diffuser)											
		Length 875mm	1771.121	.-02	1 x T16				<input checked="" type="radio"/>	<input type="radio"/>	<input type="radio"/>
		Length 1175mm	1771.128	.-02	1 x T16				<input checked="" type="radio"/>	<input type="radio"/>	<input type="radio"/>
		Length 1475mm	1771.135	.-02	1 x T16				<input checked="" type="radio"/>	<input type="radio"/>	<input type="radio"/>
Overlapping lamp arrangement											
		Length 875mm	1772.121	.-02	1 x T16				<input checked="" type="radio"/>	<input type="radio"/>	<input type="radio"/>
		Length 1175mm	1772.128	.-02	1 x T16				<input checked="" type="radio"/>	<input type="radio"/>	<input type="radio"/>
		Length 1475mm	1772.135	.-02	1 x T16				<input checked="" type="radio"/>	<input type="radio"/>	<input type="radio"/>
Acrylic diffuser											
			1764.xxx	Empty profile in metres							
			1764.000	Sawn	to size						
Blank aluminium cover											
			1765.xxx	Empty profile in metres		<input checked="" type="radio"/>	<input type="radio"/>	<input type="radio"/>			
			1765.000	Sawn	to size						

Imprint

SEEGER

Technische Leuchten e. K.
Schwerter Str. 324
D-44287 Dortmund
Germany

Tel: +49 231- 44 10 92

Fax: +49 231- 44 10 76

info@seeger-licht.de

www.seeger-licht.de

VAT ID no.: DE 124779953

Tax no.: 315/5231/0060

Amtsgericht Dortmund

(Local first-instance court)

Commercial Register No.: HRA 16 133

General Information

All previous catalogues and the statements made therein are null and void with the publication of this issue. We reserve the right to make technical and formal changes to the listed products. The catalogue may contain errors. The lighting data, technical specifications and dimensions and the representational images and drawings shown in this catalogue are unbinding. All stated measurements are approximate and, unless otherwise stated, are given in millimetres. Unless otherwise stated, illuminants do not form part of the shipment. All brand names are the property of their rightful owners and serve only for descriptive purposes.